

# Ai-WB2-12F Specification

Version V1.1.3

Copyright ©2022



## Content

1. Product Overview .....	4
1.1. Characteristic .....	5
2. Main parameters .....	6
2.1. Static electricity requirement .....	6
2.2. Electrical characteristics .....	7
2.3. Wi-Fi RF Performance .....	7
2.4. BLE RF Performance .....	8
2.5. Power .....	8
3. Appearance Dimensions .....	9
4. Pin Definition .....	10
5. Schematic .....	12
6. Antenna parameters .....	13
6.1. Schematic diagram of the antenna test prototype .....	13
6.2. Antenna S parameter .....	14
6.3. Antenna Gain and Efficiency .....	14
6.4. Antenna pattern .....	15
6.5. RF OTA parameters .....	16
7. Design Guidance .....	17
7.1. Application circuit .....	17
7.2. Recommend PCB footprint size .....	18
7.3. Antenna layout requirements .....	18
7.4. Power supply .....	19
7.5. GPIO .....	20
8. Storage conditions .....	21
9. Reflow welding curve diagram .....	21
10. Product Packaging Information .....	22
11. Contact us .....	22
Disclaimer and copyright notice .....	23
Notice .....	23

# 1. Product Overview

Ai-WB2-12F is a Wi-Fi&BT module developed by Shenzhen Ai-Thinker Technology Co., LTD. The module is equipped with BL602 chip as the core processor and supports Wi-Fi 802.11b/g/n protocol and BLE 5.0 protocol. The BL602 chip has a low-power 32-bit RISC CPU, 276KB RAM, and a wealth of peripheral interfaces, including SDIO, SPI, UART, I2C, IR Remote, PWM, ADC, DAC, PIR and GPIO etc. It can be widely used in Internet of Things (IoT), mobile devices, wearable electronic devices, smart home and other fields.

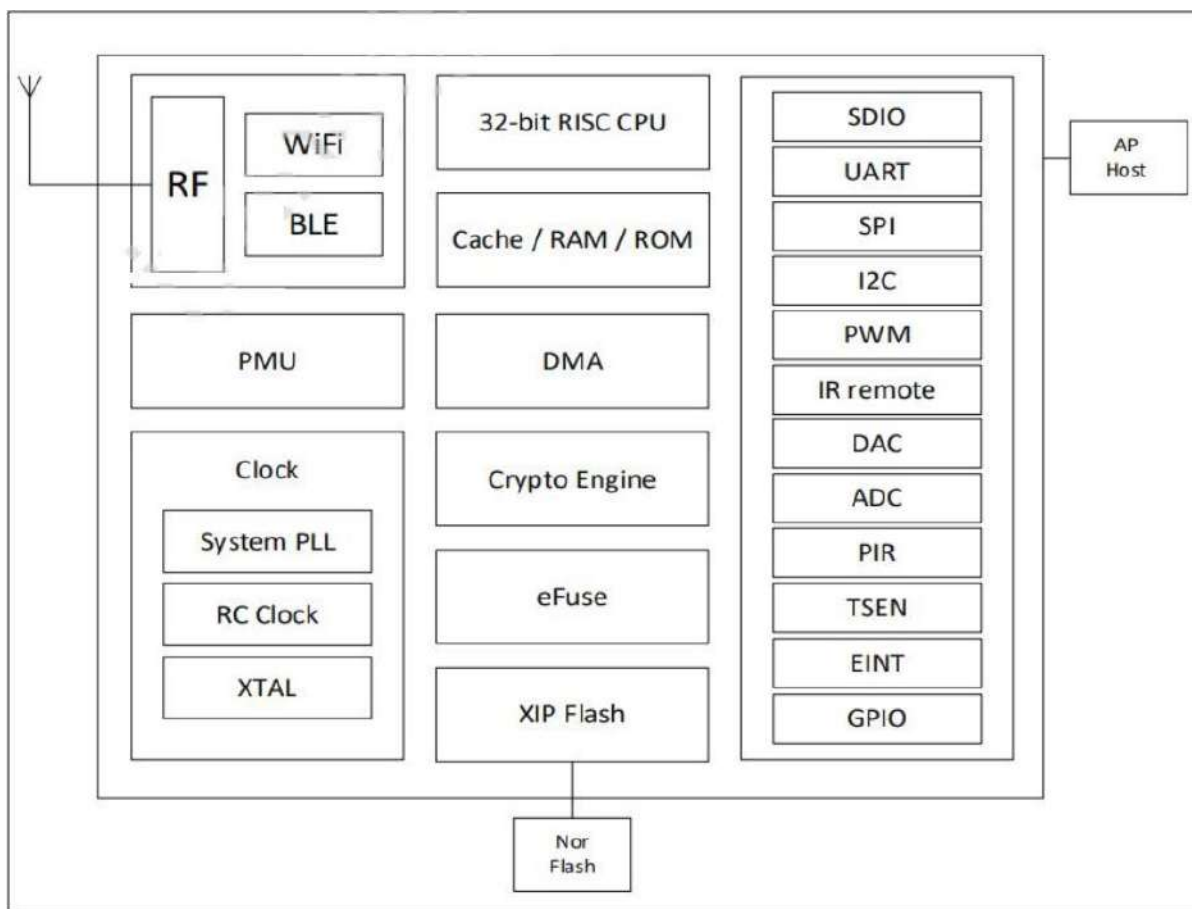

**Figure 1 Main chip block diagram**

## 1.1. Characteristic

- The package is SMD-22
- Support IEEE 802.11 b/g/n protocol
- Wi-Fi Security Support WPS/WEP/WPA/WPA2 Personal/WPA2 Enterprise/WPA3
- Support 20MHz bandwidth and Max rate is 72.2 Mbps
- Bluetooth BLE 5.0, Bluetooth Mesh
- Support Station + BLE mode、 Station + SoftAP + BLE mode
- Support 32-bit RISC CPU, 276KB RAM
- Secure start-up, supports mirroring with ECC-256 signature
- Support QSPI/SPI Flash On-The-Fly AES Decryption, support AES 128 CTR mode
- Support AES 128/192/256-bit encryption engine
- Support SHA-1/224/256
- Support true Random number generator (TRNG)
- Public key Accelerator (PKA), support large number basic operations, software provides signature, verification and other application program interface
- Support SDIO, SPI, UART, I2C, IR remote, PWM, ADC, DAC, PIR, GPIO etc
- Integrated Wi-Fi MAC/BB/RF/PA/LNA/BT
- Support a variety of sleep modes, deep sleep current 12 $\mu$ A
- Universal AT instruction for quick start
- Support secondary development, integrated Windows, Linux development environment

## 2. Main parameters

**Table 1 Description of the main parameters**

<b>Model</b>	Ai-WB2-12F
<b>Package</b>	SMD-22
<b>Size</b>	24.0*16.0*3.1(±0.2)mm
<b>Antenna</b>	on-board PCB antenna
<b>Frequency</b>	2400 ~ 2483.5MHz
<b>Operating temperature</b>	-40°C ~ 85°C
<b>Storage temperature</b>	-40°C ~ 125°C, < 90%RH
<b>Power supply</b>	Support voltage 2.7V ~ 3.6V, supply current $\geq 500\text{mA}$
<b>Interface</b>	UART/GPIO/ADC/PWM/I2C/SPI
<b>IO</b>	15
<b>UART rate</b>	Default 115200 bps
<b>Security</b>	WPS/WEP/WPA/WPA2 Personal/WPA2 Enterprise/WPA3
<b>Flash</b>	Default 4MByte, Support expansion

### 2.1. Static electricity requirement

Ai-WB2-12F is an electrostatic sensitive device. Therefore, you need to take special precautions when carrying it.



**Figure 2 ESD preventive measures**

## 2.2. Electrical characteristics

Table 2 Electrical characteristics table

Parameters	Condition	Min.	Typical value	Max.	Unit
Voltage Supply	VDD	2.7	3.3	3.6	V
I/O	VIL	-	-	0.3*VDDIO	V
	VIH	-	0.7*VDDIO	-	V
	VOL	-	-	0.1*VDDIO	V
	VOH	-	-	0.9*VDDIO	V
	IMAX	-	-	-	15

## 2.3. Wi-Fi RF Performance

Table 3 Wi-Fi RF performance table

Description	Typical value			Unit
Frequency range	2400 ~ 2483.5MHz			MHz
<b>Output Power</b>				
Mode	Min.	Typical value	Max.	Unit
11n Mode HT20, PA output power	-	16	-	dBm
11g Mode, PA output power	-	17	-	dBm
11b Mode, PA output power	-	19	-	dBm
<b>Receive Sensitivity</b>				
Mode	Min.	Typical value	Max.	Unit
11b, 1 Mbps	-	-98	-	dBm
11b, 11 Mbps	-	-90	-	dBm
11g, 6 Mbps	-	-93	-	dBm
11g, 54 Mbps	-	-76	-	dBm
11n, HT20 (MCS7)	-	-73	-	dBm

## 2.4. BLE RF Performance

**Table 4 BLE RF performance table**

Description	Typical value			Unit
Frequency range	2400 ~ 2483.5MHz			MHz
Output Power				
Rate Mode	Min.	Typical value	Max.	Unit
1Mbps	-	9	15	dBm
Receive Sensitivity				
Rate Mode	Min.	Typical value	Max.	Unit
1Mbps sensitivity@30.8%PER	-	-96	-	dBm

## 2.5. Power

The following power consumption data are based on a 3.3V power supply, 25°C ambient temperature, and measured using an internal voltage regulator.

- All measurements are made at the antenna interface with a filter.
- All transmission data are based on 100% duty cycle in continuous transmission mode.

**Table 5 Power consumption table**

Mode	Min.	AVG	Max.	Unit
Tx 802.11b, 11Mbps, POUT=+21dBm	-	260	-	mA
Tx 802.11g, 54Mbps, POUT=+18dBm	-	245	-	mA
Tx 802.11n, MCS7, POUT=+17dBm	-	230	-	mA
Rx 802.11b,packet length 1024 byte	-	65	-	mA
Rx 802.11g,packet length 1024 byte	-	65	-	mA
Rx 802.11n,Packet length 1024 byte	-	65	-	mA
Deep-Sleep	-	12	-	μA



### 3. Appearance Dimensions

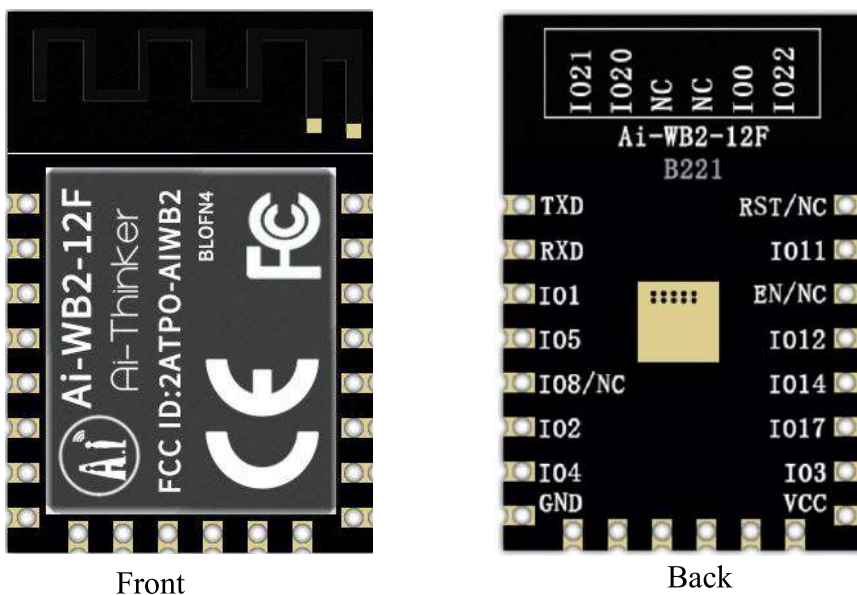

Figure 3 Appearance diagram (Rendering figure is for reference only,subject to physical objects)

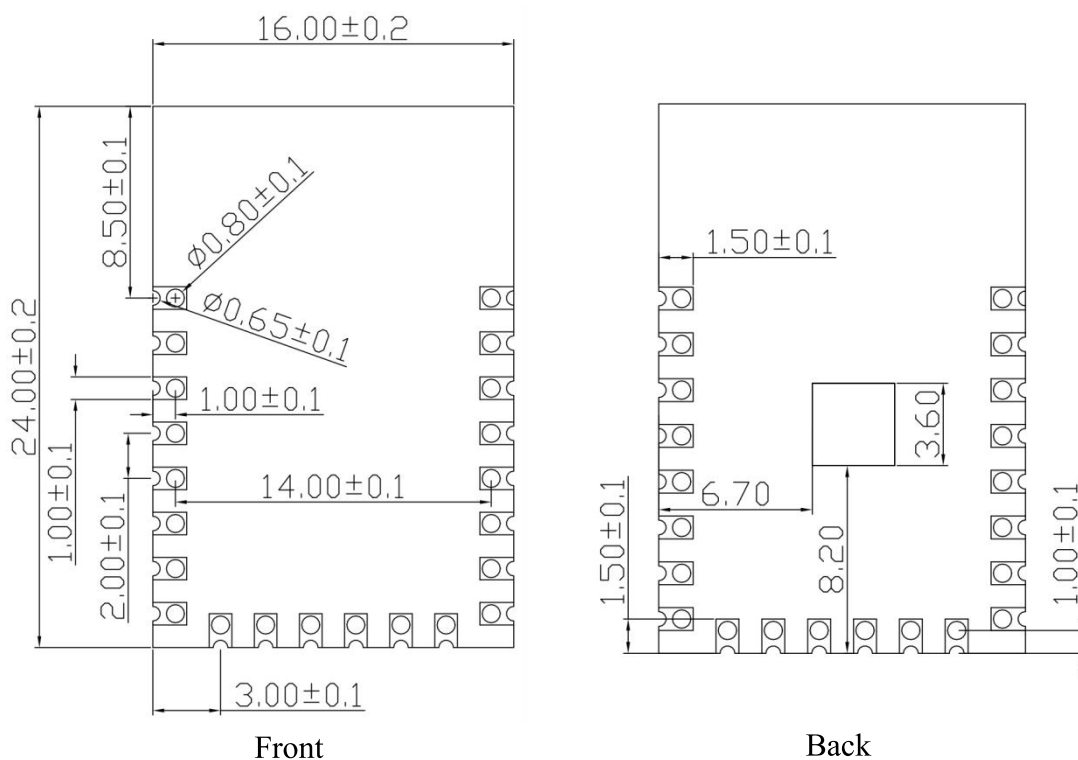

Figure 4 Dimension diagram

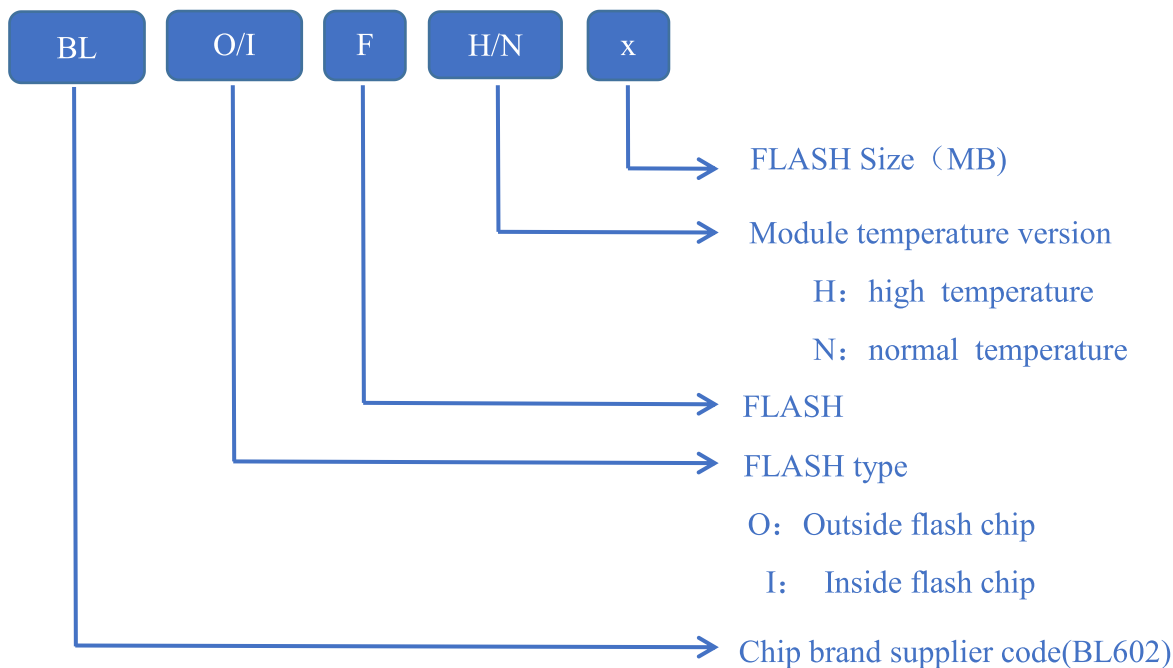

Figure 5 Shield printing information

### 4. Pin Definition

Ai-WB2-12F module is connected with a total of 22 pins, as shown in the pin schematic diagram, pin function definition table is the interface definition.

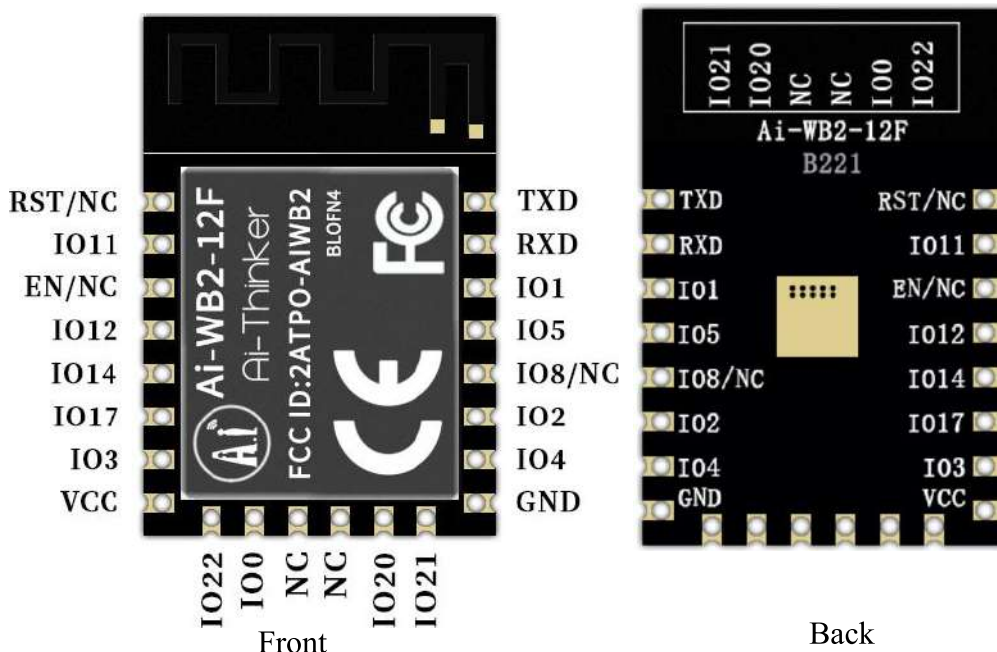

Figure 6 Schematic diagram of module pins

**Table 6 Pin function definition table**

No.	Name	Function
1	RST/NC	Default not connect, can be customized to reset pin, active-low, if you need to use it, please contact Ai-Thinker
2	IO11	GPIO11/SPI_SCLK/IIC_SDA/ADC_CH10
3	EN/NC	Default chip enable pin, active-high, cannot be used with RST at the same time
4	IO12	GPIO12/SPI_MOSI/MISO/IIC_SCL/PWM_CH2/ADC_CH0
5	IO14	GPIO14/SPI_SS/IIC_SCL/PWM_CH4/ADC_CH2
6	IO17	GPIO17/SPI_MOSI/MISO/IIC_SDA/PWM_CH2
7	IO3	GPIO3/SPI_SCLK/IIC_SDA/PWM_CH3
8	VCC	3.3V power supply; It is recommended that the output current of the external power supply be higher than 500mA
9	IO22	It is not recommended to use. It is shared with the Flash in the module. If you need to use it, please contact Ai-Thinker. GPIO22/SPI_SS/IIC_SCL/PWM_CH2/JTAG_TCK/TMS
10	IO0	It is not recommended to use. It is shared with the Flash in the module. If you need to use it, please contact Ai-Thinker. GPIO0/SDIO_CLK//SPI_MOSI/MISO/IIC_SCL/PWM_CH0/JTAG_TMS/TCK
11	NC	NC, unavailable
12	NC	NC, unavailable
13	IO20	It is not recommended to use. It is shared with the Flash in the module. If you need to use it, please contact Ai-Thinker. GPIO20/SPI_MOSI/MISO/IIC_SCL/PWM_CH0/JTAG_TMS/TCK
14	IO21	It is not recommended to use. It is shared with the Flash in the module. If you need to use it, please contact Ai-Thinker. GPIO21/SPI_MOSI/MISO/IIC_SDA/PWM_CH1/JTAG_TDI/TDO
15	GND	Ground
16	IO4	GPIO4/SPI_MOSI/MISO/IIC_SCL/PWM_CH4/ADC_CH4
17	IO2	It is not recommended to use. It is shared with the Flash in the module. If you need to use it, please contact Ai-Thinker. GPIO2/SPI_SS/IIC_SCL/PWM_CH2
18	IO8/NC	NC, unavailable. If you need to use it, please contact Ai-Thinker. Bootstrap/GPIO8/SPI_MOSI/MISO/IIC_SCL/PWM_CH3
19	IO5	GPIO5/SPI_MOSI/MISO/IIC_SDA/PWM_CH0/ADC_CH4
20	IO1	It is not recommended to use. It is shared with the Flash in the module. If you need to use it, please contact Ai-Thinker.GPIO1/SPI_MOSI/MISO/IIC_SDA/PWM_CH1
21	RXD	RXD/GPIO7/SPI_SCLK/IIC_SDA/PWM_CH2

22	TXD	TXD/GPIO16/SPI_MOSI/MISO/IIC_SCL/PWM_CH1
----	-----	--

Note:

1. At the moment of power-on, if Bootstrap GPIO8 is high, the module enters the programming mode; if Bootstrap GPIO8 is low, the module starts normally.

### 5. Schematic

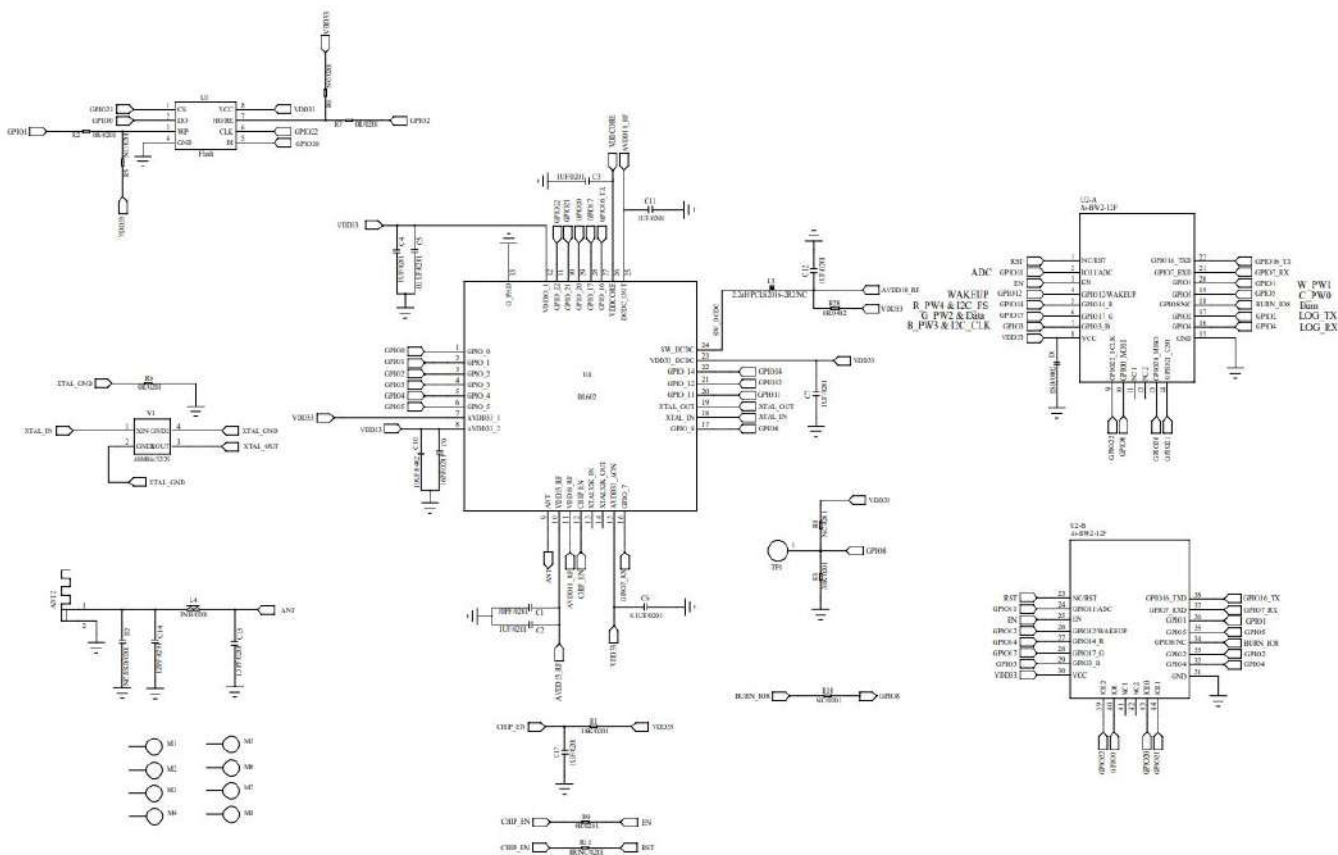

Figure 7 Module schematic

## 6. Antenna parameters

### 6.1. Schematic diagram of the antenna test prototype

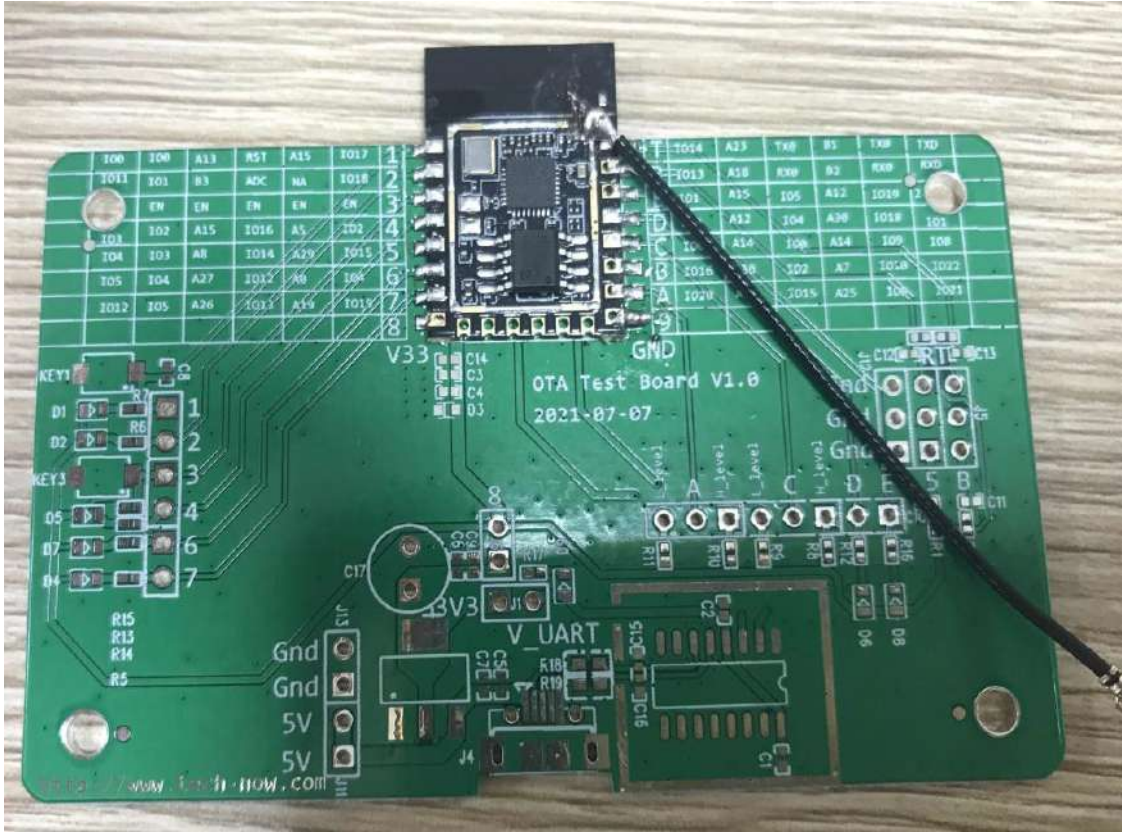

Figure 8 Schematic diagram of the antenna test prototype

## 6.2. Antenna S parameter

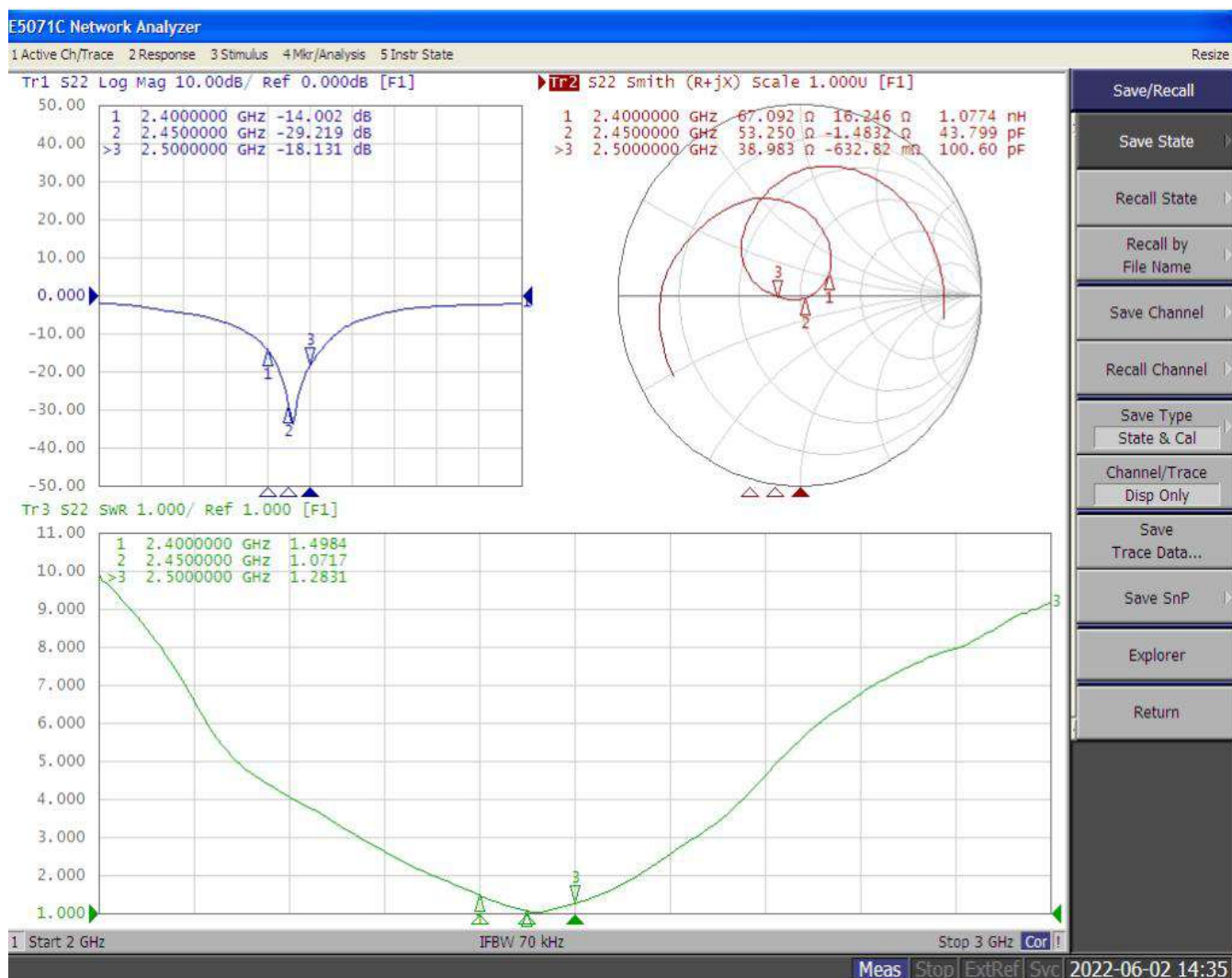

Figure 9 Antenna S parameters

## 6.3. Antenna Gain and Efficiency

Table 7 Antenna Gain and efficiency

Frequency ID	1	2	3	4	5	6	7	8	9	10	11
Frequency(MHz)	2400	2410	2420	2430	2440	2450	2460	2470	2480	2490	2500
Gain (dBi)	2.46	2.41	2.03	1.88	1.46	1.73	1.79	1.76	1.66	1.22	1.07
Efficiency (%)	61.00	62.04	60.03	62.22	58.96	64.17	63.83	62.07	60.04	54.27	52.93

### 6.4. Antenna pattern

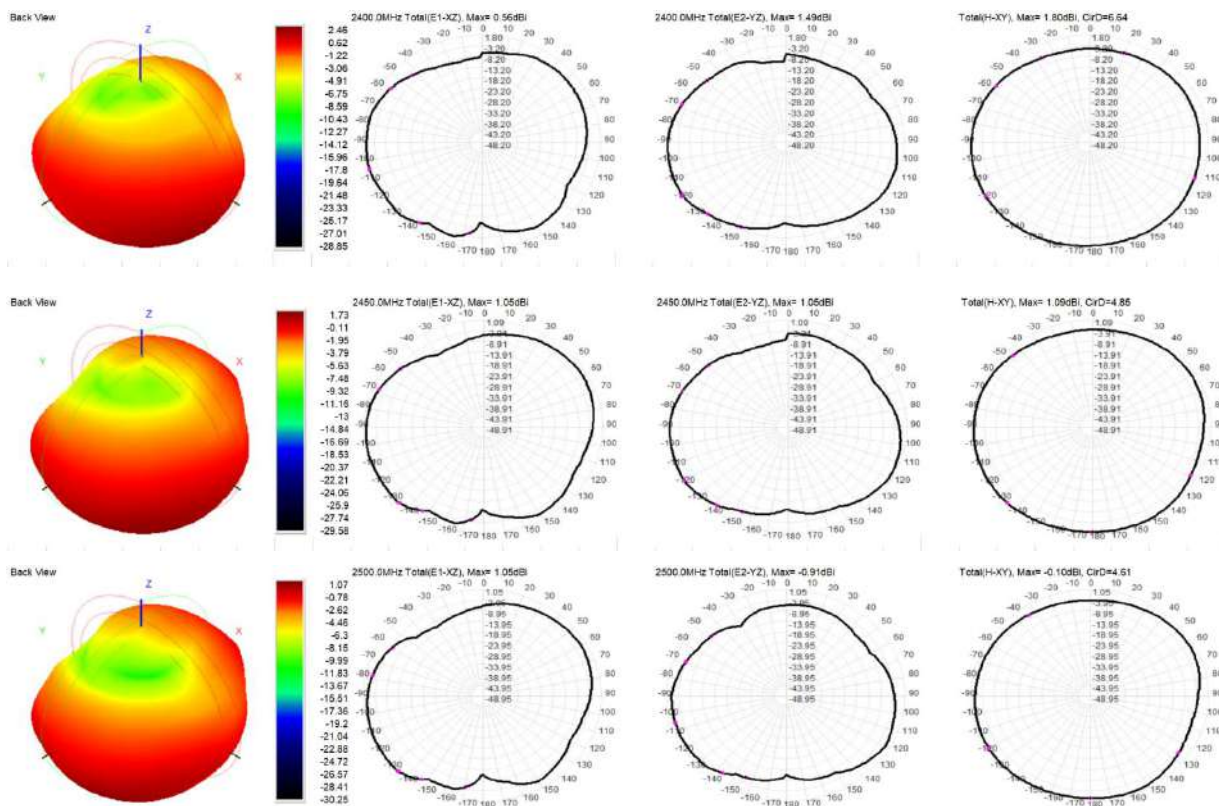

Figure 10 Antenna pattern

## 6.5. RF OTA parameters

Table 8 RF OTA parameters

Item	Mode	Rate(Mbps)	Channel	Fre.(MHz)	Data(dBm)
TRP	11b	11	1	2412	17.26
			6	2437	17.27
			13	2472	16.78
	11g	54	1	2412	15.14
			6	2437	15.03
			13	2472	14.5
	HT20	MCS7	1	2412	15.06
			6	2437	15.01
			13	2472	14.48
TIS	11b	11	1	2412	-86.78
			6	2437	-86.65
			13	2472	-87.41
	11g	54	1	2412	-73.33
			6	2437	-73.02
			13	2472	-72.8
	HT20	MCS7	1	2412	-68.43
			6	2437	-68.81
			13	2472	-67.57



## 7. Design Guidance

### 7.1. Application circuit

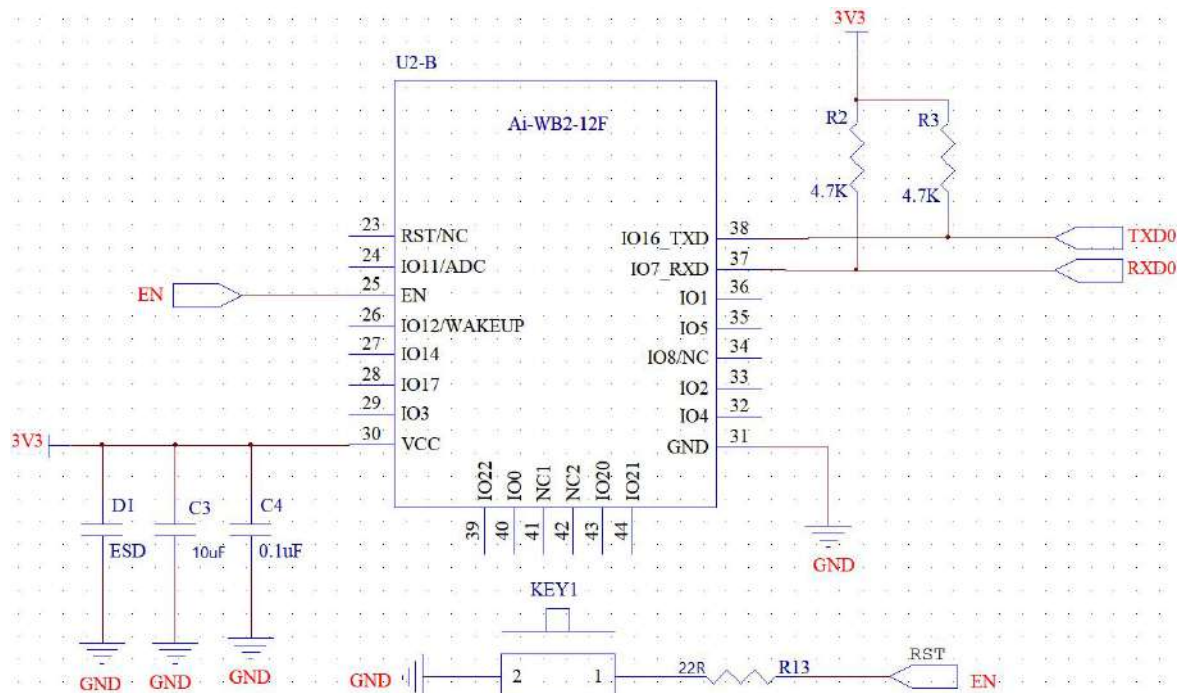

Figure 11 Application circuit diagram

- If the IO port is used as PWM, it is recommended to reserve a 4.7K pull-down resistor around the module. Especially in the application of light control, it can prevent the flashing light phenomenon at the moment of power-on start.
- The IO0/IO1/IO2/IO8/NC/IO20/IO21/IO22/RST/NC pins, which are not available by default. If you need to use it, please contact Ai-Thinker.

## 7.2. Recommend PCB footprint size

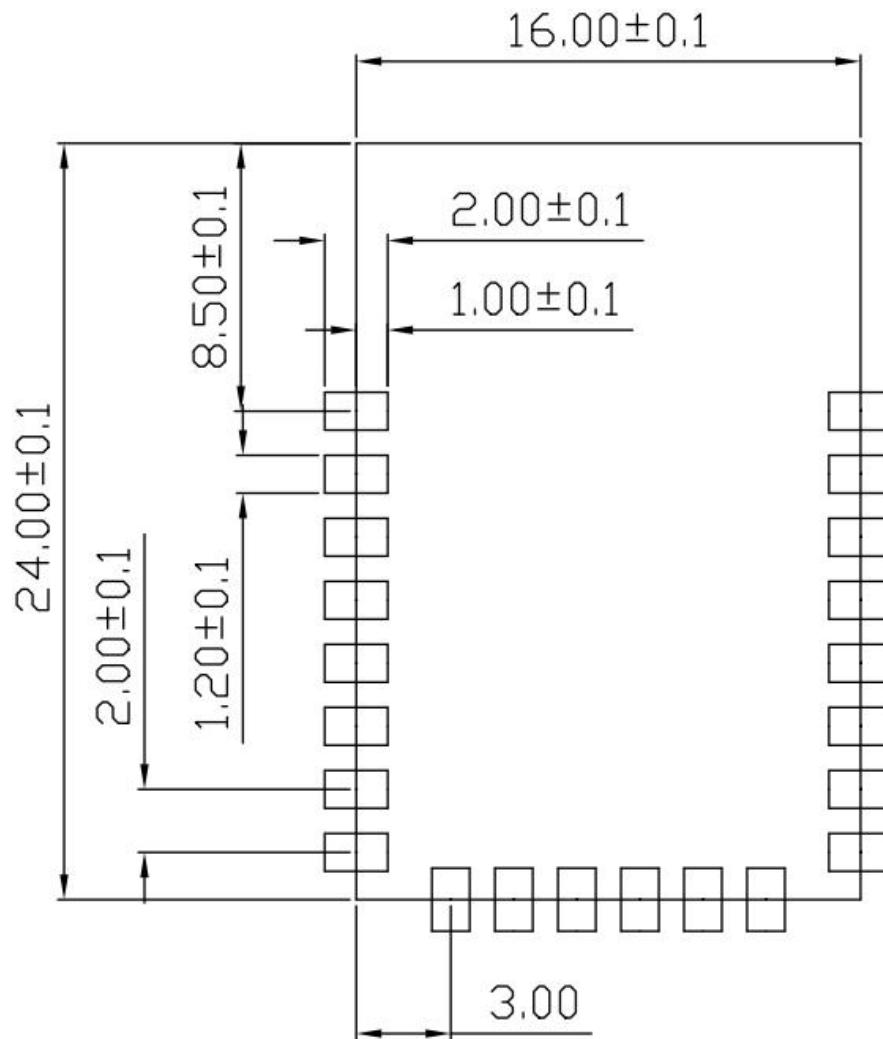

Figure 12 Recommend PCB footprint size

## 7.3. Antenna layout requirements

- The following two methods are recommended for the installation position on the mainboard:

Option 1: put the module on the edge of the motherboard, and the antenna area extends out of the edge of the motherboard.

Option : put the module on the edge of the motherboard, the edge of the motherboard at the antenna position hollowed out an area.

- In order to meet the performance of onboard antenna, it is forbidden to place metal parts around the antenna and keep away from high frequency devices.

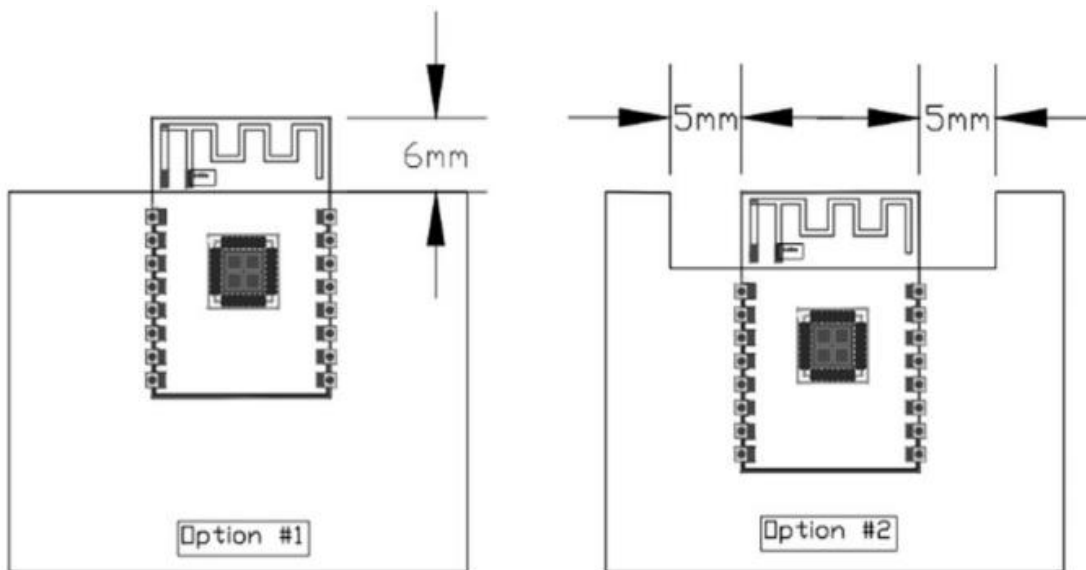

Figure 13 Antenna layout diagram

### 7.4. Power supply

- Recommended 3.3V voltage, peak current over 500mA.
- Power supply is recommend to use LDO; if the DC-DC is used, the ripple is recommended to be controlled within 30mV
- DC-DC power supply circuit proposes to reserve the dynamic response capacitance to optimize the output ripple with large load changes.
- It is recommended to add ESD devices to the 3.3V power interface.

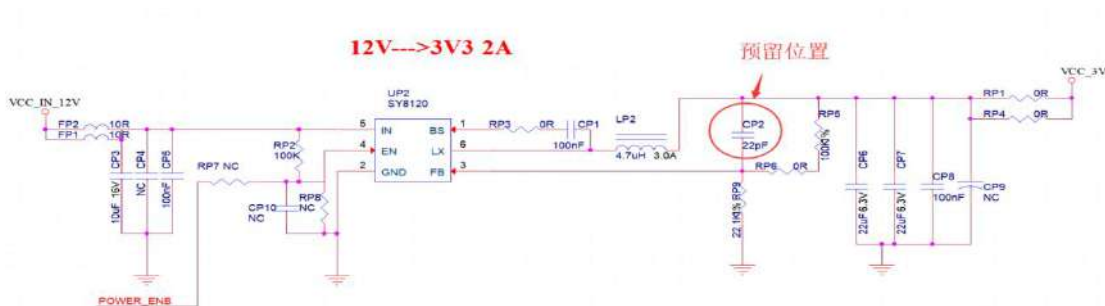

Figure 14 DC-DC step-down circuit diagram

## 7.5. GPIO

- There are some IO ports on the periphery of the module. If you need to use it, it is recommended to connect a 10-100 ohm resistor in series with the IO port. This inhibits overshoot and makes both sides level more stable. It is helpful for EMI and ESD.
- For special I/O ports to be pulled up and down, refer to the direction for use in the specifications, which may affect the module start-up configuration.
- The IO port of the module is 3.3V. If the IO level of the main control and the module do not match, a level convert circuit needs to be added.
- If the I/O port is directly connected to a peripheral port or terminals, for example, a pin row, reserve an ESD device near the terminal of the I/O cable.

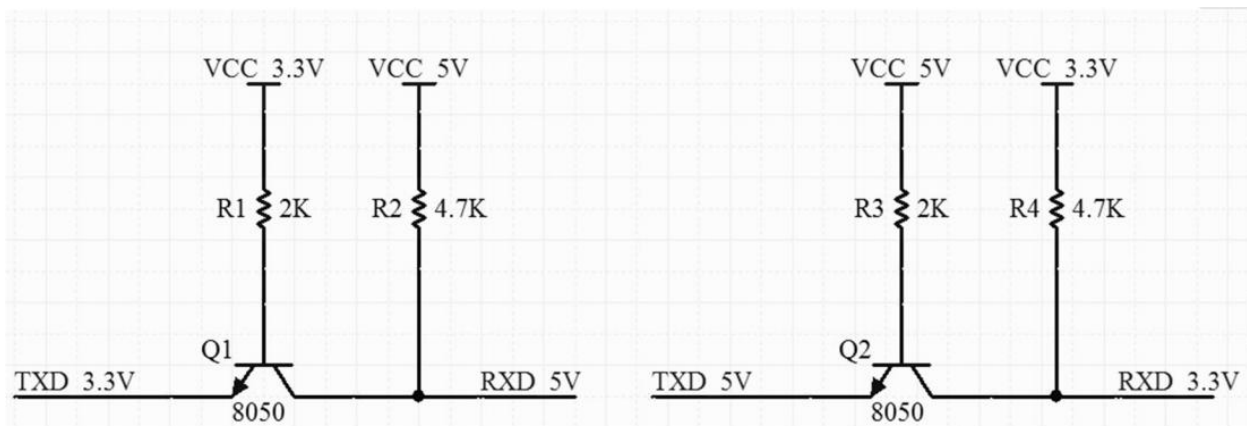

Figure 15 Level convert circuit

## 8. Storage conditions

Products sealed in moisture-proof bags should be stored in a non-condensing atmosphere of  $<40^{\circ}\text{C}/90\%\text{RH}$ .

The module has a moisture sensitivity rating of MSL 3.

After the vacuum bag is opened, it must be used within 168 hours at  $25\pm 5^{\circ}\text{C}/60\%\text{RH}$ , otherwise it needs to be baked before it can be put on line again.

## 9. Reflow welding curve diagram

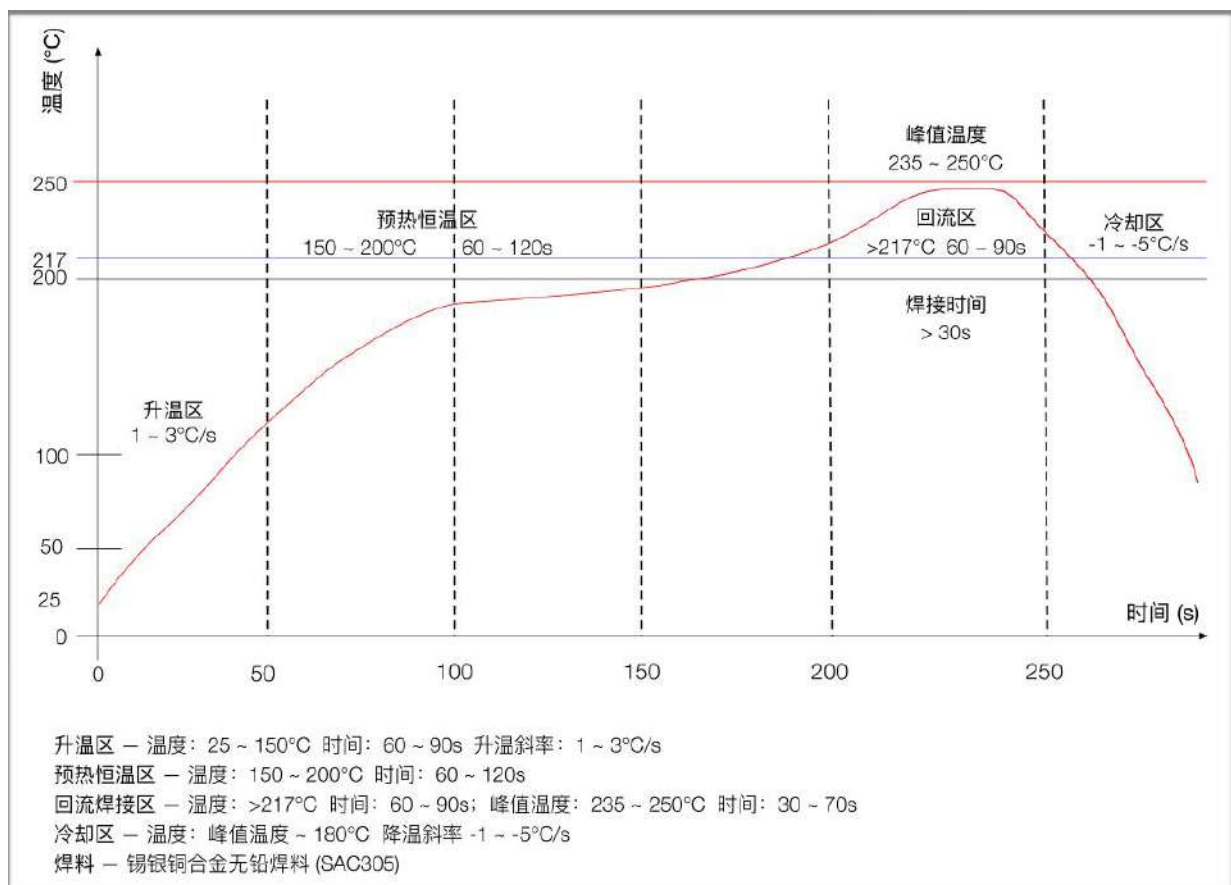

Figure 16 Reflow welding diagram