

# LCD Module SPECIFICATION

## 液晶显示模组规格书

Customer Name 客户名称	
Customer Model 客户机型	
Project Name型号	LXGD-28A1044-E-T2
Date 日期	2023-3-23
Version 版本	01

### LEAGEND LCM R&D CENTER:

制定PREPARED BY	审核CHECKED BY	核准APPROVED BY
刘畅	谭小鑫	李钰坤

### Customer's Acceptance 客户承认:

Comment 承认意见	Approved by 承认人

### Revision Record 修改记录:

Rev No 版本号	Date 时间	Description 内容
V01	2023-4-13	Preliminary Specification Release.

---

## CONTENTS 目录

- 1. General Specifications 基本规格
- 2. Pin Assignments 接口定义描述
- 3. Mechanical Drawing 模组图
- 4. Electrical Specification 电气特性
  - Absolute Maximum Ratings 极限参数
  - Typical Operation Conditions 典型工作条件
  - Backlight Circuit Characteristics 背光电气特性
  - LCD Current Consumption 液晶面板功耗
- 5. Optical Specification 光学规格
  - LCM Optical Characteristics 液晶模组光学特性
  - Measurements system 测量系统
- 6. Reliability Test Items 可靠性测试项目
- 7. QUALITY SPECIFICATIONS 检验标准
- 8. Packing and Storage Specification (Reference only)  
包装规格 (仅供参考)
- 9. Announcements 注意事项
- 10. Factory Contact Information 工厂联系信息

## 1. General Specifications 基本规格

No.	Item 项目	Specification 规格	Unit 单位	Remark
1	LCD Size 液晶面板尺寸	2.8	inch	-
2	Panel Type 面板类型	TN	-	-
3	Resolution 分辨率	240xRGBx320	Pixel	-
4	Display Mode 显示模式	Normally White	-	-
5	Number of Colors 颜色数量	262K	-	-
6	Viewing Direction 视角	12 :00 o'clock	-	Note1
7	Luminance 亮度	260	cd/m2	MIN
8	Module Size 模组尺寸	50(L)×69.2(W)×2.3(T)	mm	Note1
9	Panel Active Area 可视区域	43.2(H)×57.55(V)	mm	Note1
10	Pixel Pitch 像素尺寸	0.051(H)×0.153(V)	mm	-
11	Pixel Arrangement 像素排列	RGB Stripe		-
12	Weight 重量	TBD	g	-
13	Driver IC 驱动芯片	ST7789	-	-
14	Light Source 背光源	4 LEDs in series	-	-
15	Interface 接口方式	MCU8/16 Parallel8080	-	-
16	Operating Temperature工作温度	-20~+70	°C	-
17	Storage Temperature存储温度	-30~+80	°C	-

## 2.PinAssignments 接口定义

PinNo. Pin 序号	Symbol 符号	Function 功能描述
1	XL	Touch panel Logical foot
2	YU	
3	XR	
4	YD	
5	GND	Ground
6	VDDI	Power Supply for I/O System.
7	VDD	Power Supply for Analog, Digital System and Booster Circuit.
8	TE	Tearing effect signal is used to synchronize MCU to frame memory
9	CS	-Chip selection pin Low enable. High disable.
10	RS	-Display data/command selection pin in parallel interface. -This pin is used to be serial interface clock.
11	WR	-Write enable in MCU parallel interface. - Display data/command selection pin in 4-line serial interface.
12	RD	-Read enable in 8080 MCU parallel interface.-If not used, please fix this pin at VDDI or GND.
13	SDA	SPI interface input pin.-The data is latched on the rising edge of the SCL signal.-If not used please fix this pin at VDDI or DGND level
14	SDO	-SPI interface output pin.-The data is output on the falling edge of the SCL signal.-If not used, let this pin open.
15	REST	-This signal will reset the device and it must be applied to properly initialize the chip.-Signal is active low.
16	GND	Ground
17-24	DB0-DB7	MCU parallel interface data bus.
25-32	DB8-DB15	MCU parallel interface data bus.
33	LEDA	Anode of Backlight (2.9V-3.3V Typical:3.1V)
34-36	LEDK	Cathode of Backlight
38	IM0	-The MCU interface mode select. (MCU 接口模式选择脚)
39	IM1	-The MCU interface mode select. (MCU 接口模式选择脚)
40	IM2	-The MCU interface mode select. (MCU 接口模式选择脚)

### 3.MechanicalDrawing 模组图

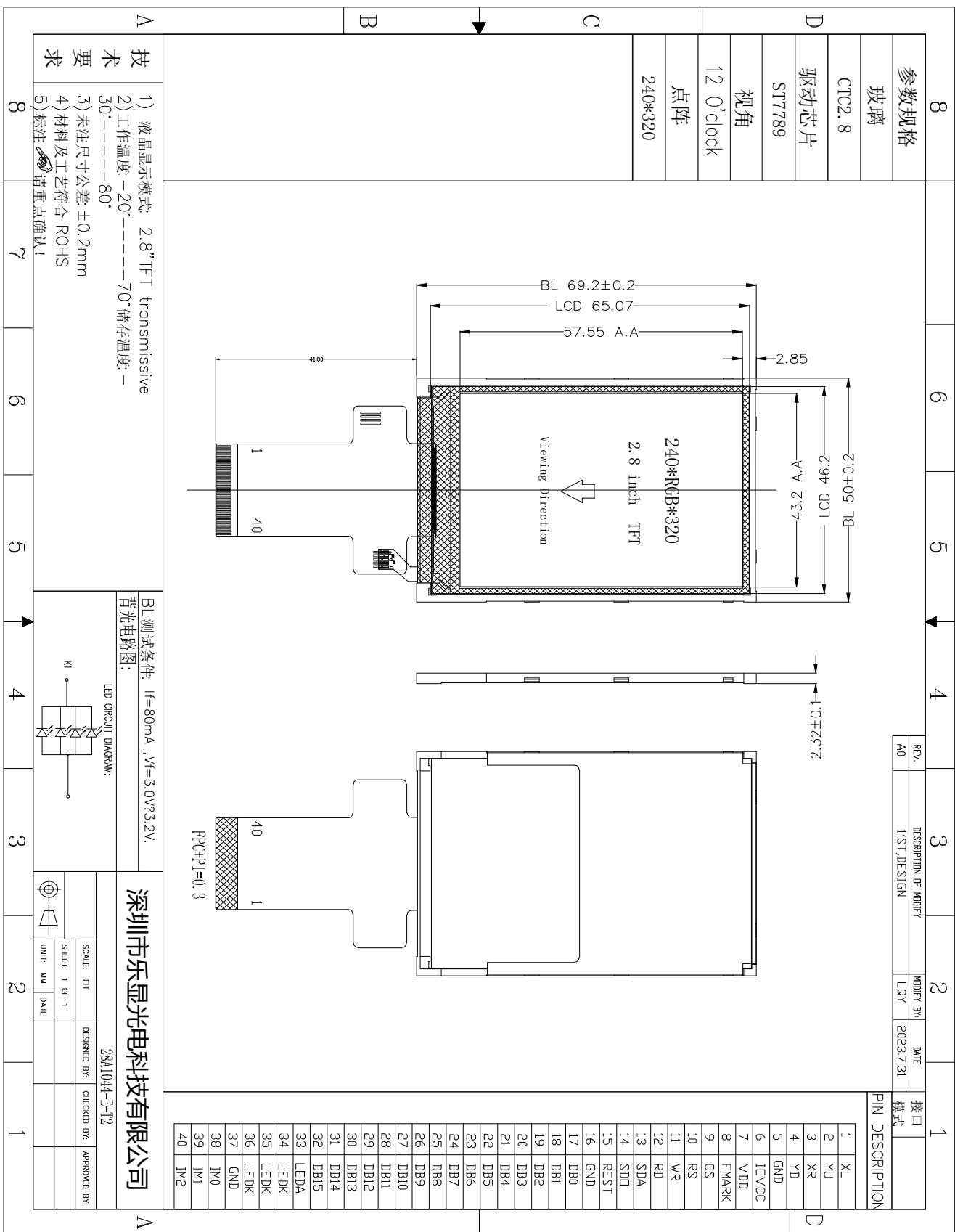

## 4. Electrical Specification 电气特性

### Absolute Maximum Ratings 极限参数

Item 项目	Symbol	Value	Unit	Remark
Analog Power Supply Voltage 模拟供电电压	VCI	2.5~+3.3	V	-
Digital Power Supply Voltage 数字电源电压	VDD	2.5~+3.3	V	-
I/O Power Supply Voltage I/O端口供电电压	IOVCC	1.65~+3.3	V	-

### Typical Operation Conditions 典型工作条件

Item 项目	Symbol	Min.最小	Typ.典型	Max.最大	Unit
Analog Supply Voltage 模拟供电电压	VCI	2.5	2.8	3.3	V
Digital Supply Voltage 数字电源电压	VDD	2.5	2.8	3.3	V
I/O Supply Voltage 接口电压	IOVCC	1.65	2.8	3.3	V
Input High Voltage 输入高电平	V <sub>IH</sub>	0.7*IOVCC	-	IOVCC	V
Input Low Voltage 输入低电平	V <sub>IL</sub>	-	-	0.3*IOVCC	V
Output High Voltage 输出高电平	V <sub>OH</sub>	0.8*IOVCC	-	-	V
Output Low Voltage 输出低电平	V <sub>OL</sub>	-	-	0.2*IOVCC	V

### BacklightCircuitCharacteristics 背光功耗

Item	Symbol	Min.	Typ.	Max.	Unit
LED Current背光电流	I <sub>B</sub>	70	80	90	mA
LED Voltage背光电压	V <sub>f</sub>	2.8	3.1	3.3	V
Power Consumption功耗	P <sub>BL</sub>	-	256	-	mW

### LCDCurrentConsumption 液晶面板功耗

Item	Symbol	Typ.	Max.	Unit
Full Mode正常模式	VCI+IOVCC	TBD	TBD	mA
测试条件: VCI=2.8V, IOVCC=2.8V; Interface 驱动类型: 行翻转或列翻转 TN Type=>All Black Pattern. TN型液晶面板=>黑色画面; IPS Type=>All White Pattern. IPS型液晶面板=>白色画面; Temperature: 25°C; 温度: 室温25摄氏度;				
Sleep Mode 休眠模式	VCI+IOVCC	-	-	uA
测试条件: VCI=2.8V, IOVCC=2.8V; DC/DC converter is enabled. Internal oscillator is started and panel scanning is started. 除IC内部晶振和面板扫描外, 其他功能都暂停工作; Temperature: 25°C; 温度: 室温25摄氏度;				

## 5. Optical Specification 光学规格

### LCM Optical Characteristics 液晶模组光学特性

Item		Symbol	Condition	Min.	Typ.	Max.	Unit
Viewing Angle Range 视角	Left	$\theta_L$	$CR \geq 10$	-	40	-	degree
	Right	$\theta_R$		-	40	-	
	Top	$\theta_T$		-	40	-	
	Bottom	$\theta_B$		-	15	-	
Response Time 响应时间		$T_{on} + T_{off}$	$\theta = \phi = 0^\circ$	-	30	-	ms
Contrast Ratio 对比度		CR	$\theta = \phi = 0^\circ$	-	250	-	-
Luminance 亮度		L	$\theta = \phi = 0^\circ$	260	-	-	cd/m <sup>2</sup>
Uniformity 均匀度		$U_L$	$\theta = \phi = 0^\circ$	80	85	-	%
Flicker 闪烁		-	-	$\leq 20\%$			-



Measurement system 测量系统  
 LCM ViewingAngle

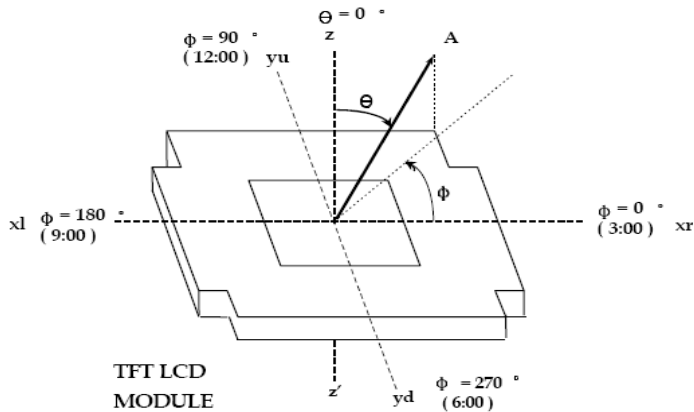

Viewing angle is the angle at which the contrast ratio is greater than 10. The angles are determined for the horizontal or x axis and the vertical or y axis with respect to the z axis which is normal to the LCD surface.

Response time

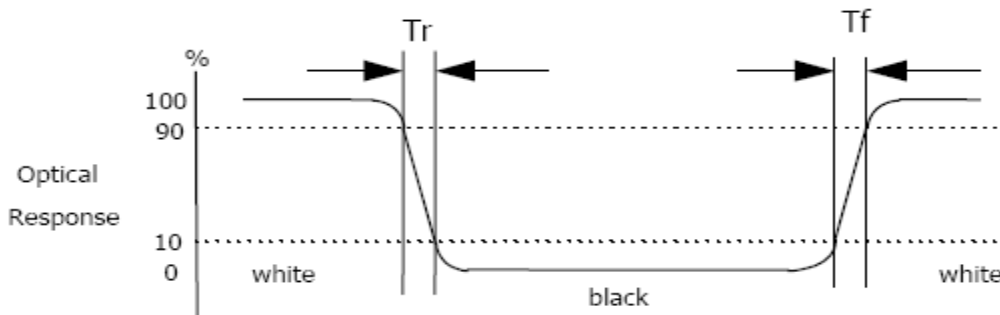

Response time is the time required for the display to transition from white to black (Rising time,  $T_r$ ) and from black to white (Falling time,  $T_f$ ) for additional information.

Contrast Ratio (CR)

Contrast Ratio (CR) is defined mathematically as:

$$\text{Contrast Ratio} = \frac{\text{Surface Luminance with all white pixels}}{\text{Surface Luminance with all black pixels}}$$

Surface luminance is the center point across the LCD surface 500mm from the surface with all pixels displaying white.

## 6. Reliability Test Items 可靠性测试项目

Test Item 测试项目	Test Condition 测试条件	Test result determinant gist 实验结果判定
High temperature storage 高温存储	80±3°C, 24H;	Inspection after 2~4hours storage at room temperature, the sample shall be free from defects: 试验结束后,已测试的LCD样品必须在室内正常温湿度环境下放置2~4个小时以上才能进行功能和外观检查, 样品不允许有以下缺陷: 1. Air bubble in the LCD; 模块中有气泡; 2. Non-display; 不显示; 3. Glass crack; 玻璃破碎; 4. The electrical characteristics requirements shall be satisfied. 需要满足模块电气性能。
Low temperature storage 低温存储	-30±3°C, 24H;	
High temperature operation 高温运行测试	70±3°C, 24H;	
Low temperature operation 低温运行测试	-20±3°C, 24H;	
High temperature /humidity 高温高湿	50°C±3°C, 90%±3%RH, 24H;	
Thermal Shock 冷热冲击	-30°C/0.5h~+80°C/0.5h for a total 24 cycles;	
Vibration Test 振动测试	Frequency 10Hz~55Hz~10Hz Amplitude: 1.5mm, X, Y, Z direction for total 1H; (Packing condition)	
ESD test 静电测试	±8KV, Air Mode, 150pF/330Ω;	

Remark: 注意:

1. The test samples should be applied to only one test item. 每个被测试的模块只能用于其中的一个测试项目。
2. Sample size for each test item is 2 pcs. 每个测试项目的样品数量为2片。
3. Failure Judgment Criterion: Basic Specification, Electrical Characteristic, Mechanical Characteristic, Optical Characteristic.  
故障判断标准: 基本规格, 电气特性, 机械特性, 光电特性。

## 7.QUALITY SPECIFICATIONS检验标准

### 1.2 检验标准

#### 1.2.1 POL外观检验标准。

点 (POL表面凹、凸点, 黑白点, 针孔状亮点的) 大小判定		判定标准	缺点区分	备注
大屏 (即面积大于等于3500 mm <sup>2</sup> 的屏)				
$\Phi \leq 0.10$		不计	次缺	两缺陷之间距离 < 10MM 时以缺点之和判定, 不计 为1cm <sup>2</sup> 允许三个
$0.15 < \Phi \leq 0.2$		1		
$0.25 < \Phi$		0		
小屏 (即面积小于3500 mm <sup>2</sup> 的屏)				
$\Phi \leq 0.2$		1	次缺	
$0.25 < \Phi$		0		
针孔状亮点 (大、小屏)				
$\Phi \leq 0.2$		1	次缺	
$0.25 < \Phi$		0		
线 (线状异物, 表面划伤, 其大小用L表示线长度, W表示线的宽度, 判定标准如下)				
大小判定		判定标准	缺点区分	备注
长 (L)	宽 (W)			
大屏 (即面积大于等于3500 mm <sup>2</sup> 的屏)				
-----	$W \leq 0.02$	不计	次缺点	两缺陷之间距离 < 10MM 时以缺点之和判定
$L \leq 3.0$	$0.02 < W \leq 0.03$	2		
$L \leq 2.5$	$0.03 < W \leq 0.05$	1		
-----	$0.05 < W$	0		
小屏 (即面积小于3500 mm <sup>2</sup> 的屏)				
----	$W \leq 0.02$	不计	次缺点	两缺陷之间距离 < 10MM 时以缺点之和判定
$L \leq 2.0$	$0.02 < W \leq 0.03$	2		
$L \leq 1.0$	$0.03 < W \leq 0.05$	1		
-----	$0.05 < W$	0		

POL表面气泡	判定标准	缺点区分	备注
点状气泡 (大、小屏, $\Phi$ 表示气泡的大小)			
$\Phi \leq 0.2$	1	次缺	

线状气泡 (大、小屏, L表示气泡的长度, W表达气泡的宽度)				
大小判定		判定标准	缺点区分	备注
长 (L)	宽 (W)			
$L \leq 1$	$W \leq 0.1$	不计	次缺点	两缺陷之间距离 <10MM 时以缺 点之和判定
$L \leq 5$	$W \leq 0.1$	2		
$L \leq 10$	$W \leq 0.1$	1		
-----	$0.1 < W$	0		

POL的其它不良项目及判定标准 (所有型号, 大、小屏)			
不良项目	判定标准	缺点区分	备注
贴附位置偏移	不超出玻璃边沿, 不进入可视区判定1 / 2 OK	次缺	其中保护膜漏贴 为主缺
保护膜不良	破损, 翻卷, 漏贴不可		
水纹	不进入显示区 OK		
易揭撕膜标签	漏贴, 贴附位置与样品承认书不附;		
边框 气泡	没有进入显示区属于OK		

## 1.2.2 LCD的不良判定标准

### 1.2.2.1 LCD显示时点、线状不良判定标准

点 (显示时玻璃内的凹、凸点, 黑、白点, 针孔状亮点、亮斑的) 大小判定		判定标准	缺点区分	备注
大屏 (即面积大于等于3500 mm <sup>2</sup> 的屏)				
$\Phi \leq 0.10$	不计	次缺	两缺陷之间距离<10MM时以缺点之和判定, 不计为1cm <sup>2</sup> 允许三个	
$0.10 < \Phi \leq 0.15$	2			
$0.15 < \Phi \leq 0.20$	1			
$0.25 < \Phi$	0			
小屏 (即面积小于3500 mm <sup>2</sup> 的屏)				
$\Phi \leq 0.2$	1	次缺		
$0.25 < \Phi$	0			
针孔状亮点 (大、小屏)				
$\Phi \leq 0.2$	1	次缺		
$0.25 < \Phi$	0			
亮斑 (大、小屏, 扩散点)				
$\Phi \leq 0.10$	不计	次缺	两缺陷之间距离<10MM时以缺点之和判定, 不计为1cm <sup>2</sup> 允许三个	
$0.10 < \Phi \leq 0.15$	2			
$0.15 < \Phi \leq 0.20$	1			
$0.25 < \Phi$	0	次缺		
线 (显示时屏内的线状异物, 屏划伤、纤维等, 其大小用L表示线长度, W表示线的宽度, 判定标准如下)				
大小判定		判定标准	缺点区分	备注
长 (L)	宽 (W)			
大屏 (即面积大于等于3500 mm <sup>2</sup> 的屏)				
-----	$W \leq 0.02$	不计	次缺	两缺陷之间距离<10MM时以缺点之和判定
$L \leq 3.0$	$0.02W \leq 0.03$	2		
$L \leq 2.5$	$0.03 < W \leq 0.05$	1		
-----	$0.05 < W$	0		
小屏 (即面积小于3500 mm <sup>2</sup> 的屏)				
----	$W \leq 0.02$	不计	次缺	两缺陷之间距离<10MM时以缺点之和判定
$L \leq 2.0$	$0.02 < W \leq 0.03$	2		
$L \leq 1.0$	$0.03 < W \leq 0.05$	1		
-----	$0.05 < W$	0		

## 7. Packing and Storage Specification (Reference Only) 包装存储

### Packing Method 包装方法

(1)

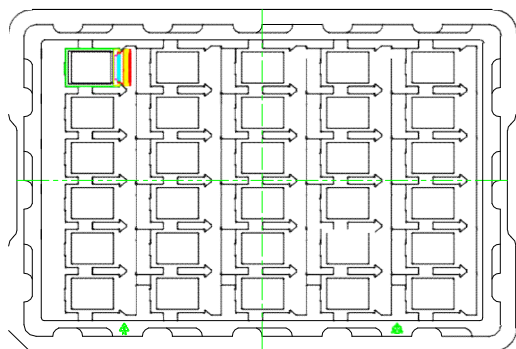

(3)

(2)

Use empty tray



Put products into the tray



(4)

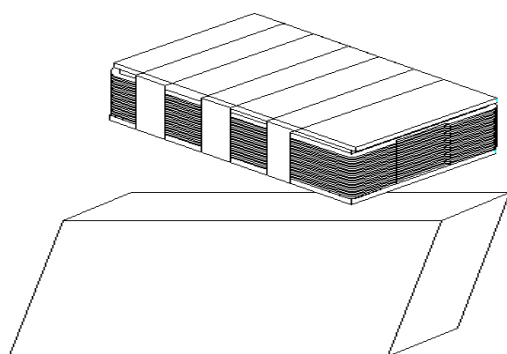
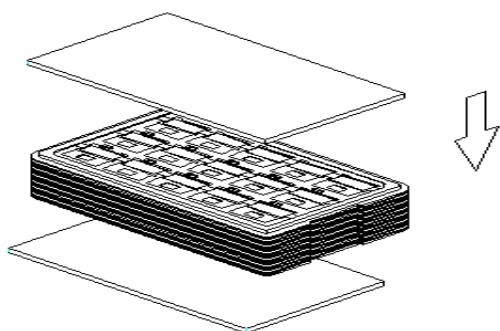

(5)

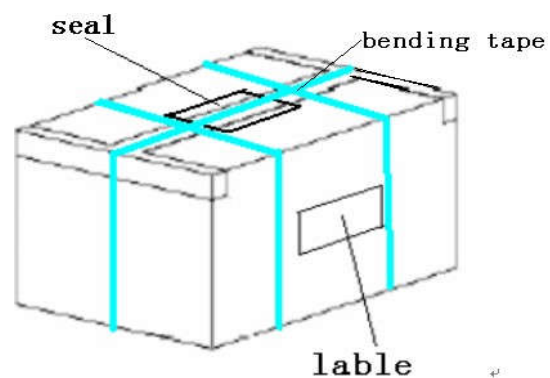
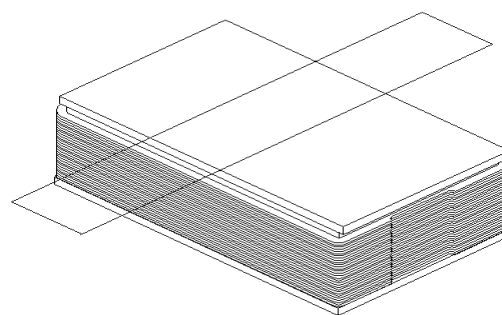

(6)

1. Put module into tray cavity. 把模块放进托盘.
2. Tray stacking. 托盘叠装.
3. Put 1 foam under the tray stack and 1 foam above. 在托盘上下放卡板.
4. Fix the cardboard to the tray stack with adhesive tape. 绑胶带.
5. Put the tray stack into carton. 把绑好的托盘放进纸箱.

---

6. Carton sealing with adhesive tape. 封纸箱.

(此包装仅供参考, 具体按实际包装为准)

### **Storage Method 存储方法**

1. Store in an ambient temperature of  $23^{\circ}\text{C}\pm 5^{\circ}\text{C}$ , and in a relative humidity of  $55\%\pm 15\%$ .

Don't exceed 12 months and expose to sunlight or fluorescent light.

存储环境温度为 $23\pm 5^{\circ}\text{C}$ , 相对湿度为 $55\%\pm 15\%$ , 存储不能超过12个月, 不要长时间暴晒。

2. Store in a clean environment, free from dust, active gas, and solvent.

存储在一个干净的环境, 不受灰尘, 活性气体和溶剂污染。

3. Store in antistatic container.

存储在防静电环境。

### **8. Announcements 注意事项**

1. Do not attempt to disassemble or process the LCD module.

请勿拆卸液晶显示模块。

2. Do not make extra holes on the printed circuit board, modify its shape or change

the position of component to be attached.

不要在印制电路板上钻额外的孔, 修改形状或更改印制线路板上元件的位置。

3. Except for soldering the interface, do not make any alterations or modifications with

a soldering iron; Ensure welding temperature at  $320^{\circ}\text{C}$  to  $350^{\circ}\text{C}$ , the welding time control

within the 10 s, welding note don't stay too long in the same place to avoid scald FPC.

除焊接接口外, 不要用烙铁做任何更改; 焊接温度保证在  $320^{\circ}\text{C}$ - $350^{\circ}\text{C}$ , 焊接时间控制在

10S 以内, 焊接时注意不要在同一处停留时间太久以免烫伤 FPC。

4. Other matters in not clear before use, please contact our staff to guide.

其他事项在不清楚使用之前, 请联系我司人员指导进行。